

Vibration Isolation and Control in Civil Engineering

Dr. Bharat Bhushan Prasad

Department of Civil Engineering, Ajay Kumar Garg Engineering College, 27 Km Stone,
NH-24, Ghaziabad 201009 UP India
bhushanbharat1947@gmail.com

Abstract -- For any given frequency above the natural frequency, an isolator with a lower natural frequency will show greater isolation than one with a higher natural frequency. The best isolation system for a given situation depends on the Damping causes energy dissipation and has a secondary effect on natural frequency.

Keywords: Resonance, Stiffness, Mass, Transmissibility, Isolation.

I. INTRODUCTION

The reduction of unwanted vibrations in a system is known as vibration control. A vibrating machine foundation may adversely affect its own performance and may cause distress to other machines in its neighborhood and the adjoining structures through transmission of energy associated with propagating waves. Thus, reduction of vibrations amplitude and arresting of propagating waves to prevent damage to adjoining structures may therefore be desirable in many such cases.

The system is said to be isolated if the magnitude of the transmitted force is less than the exciting force. The presence of an elastic element induces further vibration of the machine. A vibration isolator should be designed to reduce the transmitted force to a desired tolerable level while keeping the machine vibration at an acceptable level. An isolated system is said to be active or passive depending upon whether or not external power is required for isolators to perform its function.

The isolation is expressed in terms of force or motion. The lesser the amount of force or motion transmitted to the foundation, the greater is the isolation. There are two basic requirements for an isolator, firstly, there should be no rigid connection and, secondly, the isolators remain together even if the damping material such as rubber, cork fails. Thus, an important consideration in the design of machine foundation is to provide proper vibration isolation if required.

The issues of vibration isolation and control shall be addressed in this paper on soil dynamics stand point. The structural control is generally employed in cases involving dynamic load and seismic forces, so that the structure response may under

permissible limits. More recently, the structure control is in use, however, the basic concepts of structural control are not new. In other branches of engineering, like electrical, aeronautical and mechanical engineering, control theory and practice have been applied successfully in a variety of disciplines. In earthquake engineering such control schemes are of great importance specially for reducing earthquake structural responses. A brief description of structural control, base isolation, and seismic isolation of bridges shall be presented in this chapter.

II GENERATION AND PROPAGATION OF VIBRATIONS

Vibration propagation may be listed as follows:

1. Vibrations develop in equipment during operation.
2. Equipment vibrations are transferred to the foundation and it begins to vibrate.
3. Foundation vibrations are transmitted to the ground supporting it, leading to ground vibrations. These vibrations propagate as waves either along the surface or through the ground.
4. Waves reaching the building first cause vibrations in the foundation and then in the building, gradually increasing in amplitude.
5. The precision instrument at that location in the building is affected by the vibrations and may lose its functionality.

III. ENERGY DISSIPATION MECHANISM

The energy dissipation mechanism is generally felicitated by provision of damping. The types of damping in a physical system are the following:

- Structural (or solid) damping
- Coulomb or dry friction damping
- Viscous damping.

IV. TECHNIQUE TO PREVENT VIBRATIONS

Following preventive measures against vibrations are applicable to the entire process of generation and propagation of vibrations mentioned above.

1. Minimize the force of vibrations developed in the equipment or the sources (improve or replace the equipment).

2. Increase the natural frequencies of the system using piles, etc. or increase the foundation mass. Suppress the vibrations in the equipment-foundation-ground system by some improvements
3. Insert some cushioning material between the equipment foundation and the ground to preclude propagation of vibrations to the ground (elastic support method).
4. Propagation of vibrations transmitted to the ground can be limited through trenches or burying a heavy mass in between or using attenuation. This method is generally not so effective.
5. Minimize the response of each part of the building to vibrations. The rigidity of structure should be increased or decreased to preclude resonance with vibrations transmitted by the ground. Also, remove ricketiest of fixtures such as windows or doors.
6. Propagation of vibration from the building can be minimized through provision of elastic supports to the said equipment.
7. As we apply the above measures, adequate measures are chosen in individual cases. Only one measure may suffice in some cases while a combination of measures may be required in others. We may also encounter situations in which a particularly effective measure cannot be applied due to cost or physical constraints.

V. BASIC CONCEPT OF VIBRATION ISOLATION

This is essentially based on vibration isolation principle of an SDF system.

The dynamic forces generated by machines are unavoidable. However, it is desirable that effects on a dynamical system can be minimized by proper isolator design. Thus, the objective of an isolation system is to protect a delicate object from excessive vibration and to prevent the vibratory forces generated by the machine from being transmitted to its surroundings. Often machines are directly bolted to the floor, and as such when the machine is subjected to harmonic excitation mainly from a rotating unbalance, the harmonic force is directly transmitted to the bolts and the foundation. If the amplitude is large, it can lead to severe damage to bolts and its supporting structure. The transmitted force can be reduced considerably by mounting the machine on elastic foundation as shown in Figure 1.

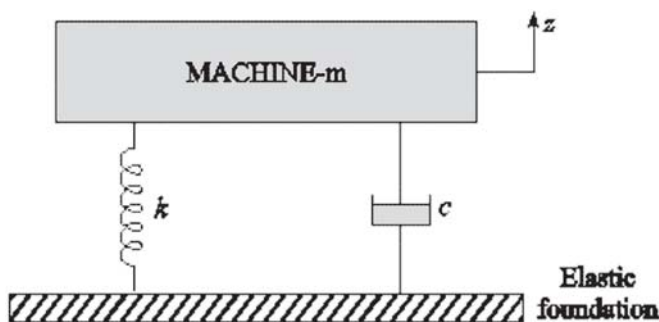

Figure 1. Machine supported on elastic foundation.

The elastic foundation is modeled as a spring k and viscous damping c . The dynamic force transmitted to the floor from the elastic foundation is obtained using transmissibility ratio.

Transmissibility is the ratio of the magnitude of the repeating component of the force transmitted to the support to the magnitude of the excitation force. Vibration isolation is achieved if the transmissibility ratio is less than one. Figure 2 shows the variation of Tr with frequency ratio r .

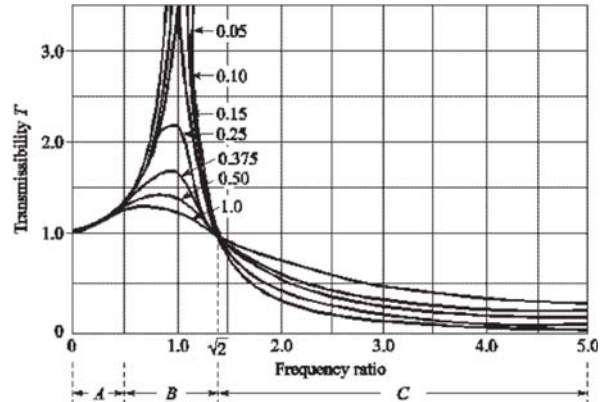

Figure 2. Range of frequency ratio for vibration isolator (Tr s Vrs frequency ratio).

The range of frequency ratio is classified as follows

- A Stiffness controlled
- B Damping controlled
- C Mass controlled

The following recommendations and observations are important for vibration isolation and control

- I. Vibration isolation is possible if $r > \sqrt{2}$.
- II. For $r > \sqrt{2}$, a larger % isolation may be obtained.
- III. Increased damping hinders isolation. For $r > \sqrt{2}$, greater value of r leads to larger value of Tr .
- IV. Damping is still essential even when it hinders isolation, as damping limits the amplitude and Tr , as resonance is passed. However, damping should be as low as possible.

VI. STRUCTURAL CONTROL

Structural control is basically the modification of the properties of a structure as a building or bridge in order to achieve a structurally desirable response to a given external load. G.W. Housner (1992), and Iemura, H. *et al.* (1992, 1996) have explained with great excellence the application the concept of structure control. In 1994, the First World Conference on Structural Control was held in Pasadena, California and it was followed by the Second World Conference on Structural Control in 1998 in Vgoto, Japan. A special theme session entitled “Seismic Response Control of Structural Systems” was held at the Ninth World Conference in Earthquake Engineering in 1988 in Japan.

Structural control minimizing the dynamic response during earthquakes has attracted a great interest worldwide. G.W. Housner, (1992) has reported that it is worth noting that a very early application of structural control response in earthquake was that by John Niline when he was Professor of Engineering at the Imperial Engineering College in Tokyo in 1880. He put a small structure on ball bearing of rough, irregular shape, thus isolating the structure from the ground and also providing some damping. However, in Japan even in reality several centuries earlier the structural control was applied to construction of a Goyunoto (pagoda) by an unknown engineer.

Figure 3 shows a five storey tall pagoda, constructed of closely fitting, mortised wooden beams and columns. During an earthquake, the vibrations of such a vertical cantilever structure would produce bending movement that could not be resisted by tension at the mortised joints. To overcome this weakness, a long wooden pole was suspended freely from the upper part of the pagoda to act a pendulum if the pagoda was into motion by an earthquake. The weight of the pole exerted a compressive prestress on the pagoda, thus increasing the bending resistance. The bottom of the pole extended into a cylindrical hole in the ground that was of larger diameter than the pole. Thus, when the pagoda was excited into vibrations by an earthquake, some of the vibrational energy would be transferred into oscillations of the pole and the impact of the pole on the sides of the hole would dissipate energy.

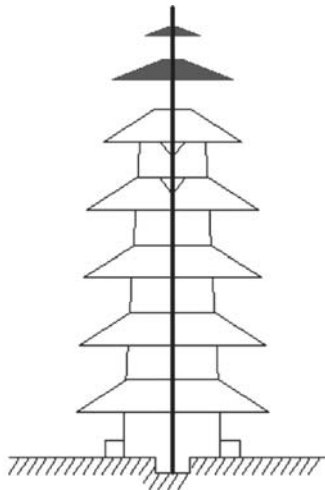

Figure 3. Wooden pagoda with suspended pole that is free to oscillate. (After Tanabashi, R, 1960).

VII. MECHANICS OF STRUCTURAL CONTROL

The system for control of structural response can be classified in the following types, namely,

- Active control system
- Passive control system
- Hybrid control system
- Semi-active control system

Active control system

Owing to recent advances in information technology, seasoning and digital techniques, active and semi-active control methods of dynamic response of structures are emerging and a few are being used in building and bridges. Figure 4 shows schematic diagram of active control system.

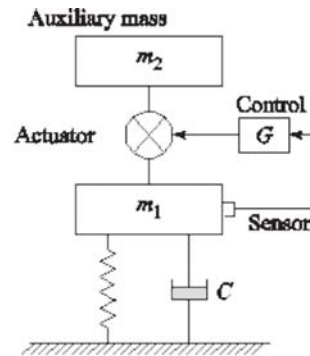

Figure 4. Schematic Diagrams for Active Control System.

Passive control system

In passive control system as shown in Figure 5 provision is made for dynamic absorbers of vibrations, systems, for additional energy dissipation wherein the controlling forces develop at the location of installation of the mechanism itself. The energy necessary for generation of these forces is provided through the motion of the mechanism during the dynamic excitation. However, the relation motion of the mechanism defines the amplitude and the direction of the controlling force.

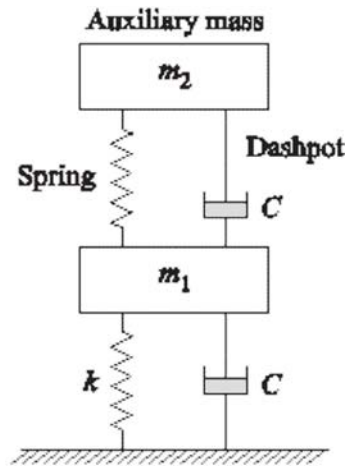

Figure 5. Schematic Diagrams for Passive Control System.

Hybrid control system

Hybrid control method as shown in Figure 6 is essentially combination of active and passive devices. The hybrid control system works well by utilizing the advantages and avoiding the disadvantages of the active and passive method. In hybrid control higher levels of performance may be attained. One example of a hybrid system is a TMD (turned mass damper)

with actuators that are put between the TMD mass and its support to increase the effectiveness of the TMD. Figure 5 and 6 illustrates a schematic diagram of passive TMD, active AMD (active mass damper) and hybrid ATMD (actual turned mass damper).

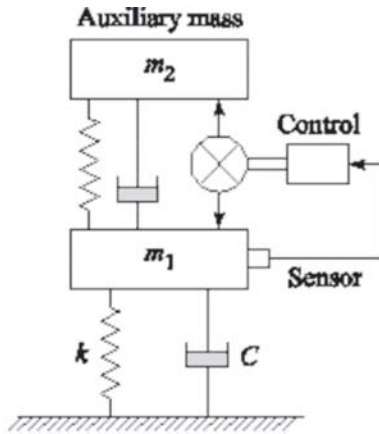

Figure 6. Schematic Diagram for Hybrid Control System.

Semi active control system

Semi active control system combines the best features of both passive and active approaches, offering the reliability of passive devices and maintaining the versatility and adaptability of fully active system. Various semi active devices have been purposed that utilize forces generated by surface friction or viscous fluids to dissipate vibratory energy in a structural system.

Fully active structural control

Figure 7 shows the basis configuration for structural control. The structural control as shown in Figure 7 essentially consists of sensors, controllers, and actuators. Sensors are used to measure either external excitations or structural responses or both. Controllers process the measured information, whereas actuators are used to produce the required forces and are usually powered by the external energy sources. When only the structural response variables are measured, the control configuration is referred to as feed base control as closed-loop control, because the structural response is continually monitored.

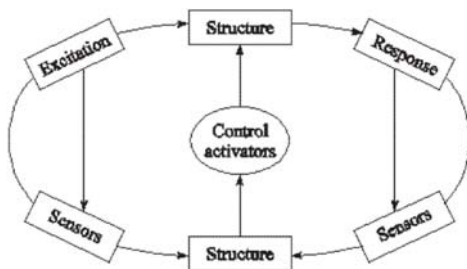

Figure 7. Schematic Diagram of Structural Control

The open loop control results when the control forces are regulated only by the measured excitation (Chen, W.F., 2002). Finally, the five principles of seismic control for structural response may be expressed as

1. Isolating the structure from the seismic input-energy
2. Isolating the natural frequencies of the structure from the predominant seismic power components
3. Providing non-linear structural characteristics and establishing a non-stationary state non-resonant system.
4. Utilizing an energy absorbing mechanism
5. Supplying control force to suppress the structural response.

VIII. BASE ISOLATION

Conventionally, there are provisions to design the building/structure on the following concepts of increasing the resistance of the structures adjoint seismic shaking by employing

- Concepts of shear wall
- Braced frames
- Moment resistant frames.

In the conventional methods, there is either higher floor accelerations for stiff buildings or large interstory drifts for flexible building. As such, the building contents and non-structural components may suffer significant damage during a major earthquake, even if structure itself remains basically intact. This is not acceptable especially for those buildings where contents are more costly than the building itself. In order to minimize interstory drifts, in addition to reducing floor accelerations, the concept of base isolation is increasable being used. Base isolation has also been referred to as passive control, as the control of structural motions is not exercised through a logically driven external agency, but rather through a specially designed interface at the structural base or within the structure, which can reduce or filter out the forces transmitted form the ground [Chen, W.F, 2002].

More recently, base isolation has become a practical strategy for earthquake-resistant design. Despite wide variation in detail base isolation technique follows two basic approaches with certain common features Chopra (2002). In the first approach, the isolation system introduces a layer of low lateral stiffness between the structure and the foundation. As such the structure has a natural period that is much longer than its fixed-base natural period. The second type of isolation uses rollers or sliders between the foundation and the base of the structure. Base isolation provides an alternative to the conventional fixed-base design of structures and may be cost effective for some new buildings in locations where very strong ground shivering is likely. It is an alternative for infrastructure buildings specially hospital, emergency communication centers and other important buildings. Base isolation essentially minimizes the need for such strengthening measured (like shear walls, frames and bearings) by reducing the earthquake forces imported to the building.

IX. PRINCIPLE OF ISOLATION SYSTEM

When a building or a structure is subjected to a strong ground motion during earthquakes, the energy of the structure can be expressed as

$$AE + BE + CE = DE \tag{1}$$

where

AE = kinetic energy

BE = dissipated energy

CE = strain energy

and DE = seismic input energy

In the above energy equation, kinetic and strain energy and the portion of the energy of the structure that is recoverable, whereas BE is dissipated energy consisting of viscous energy and hysteresis energy. For a fixed-base building structure, when the seismic input energy is not so large, the energy input to the structure will be dissipated in the form of viscous energy. However, when a strong earthquake occurs, if all the input energy cannot be dissipated by the viscous damping, then the residual energy will be dissipated in the form of hysteretic energy. If the structural has been designed to have sufficient ductility, then it may undergo plastic deformations in certain joints, members as specially added components, but the phenomenon of collapse must be avoided. This is what is popularly known as the ductility concept of design for the traditionally fixed-base structures.

The dynamic characteristic of a base-isolated building can be represented by a single storey building with a linear isolator as shown in Figure 8.

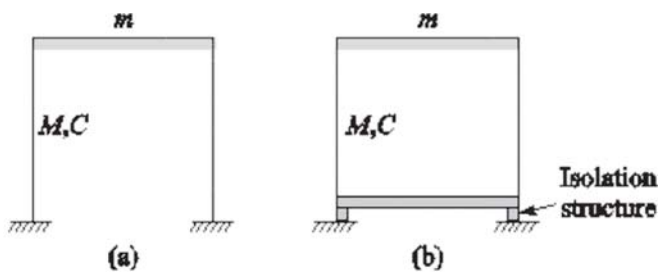

Figure 8. Roof System for Isolated Structure.

Two additional factors should be considered before base isolation is regarded as feasible means for a seismic design (Mayes and Naeim, 2001); First, most benefits of base isolation can be achieved only for stiff structure, i.e. with a fixed-base fundamental period of 1.0 second or less. For these structures, the fundamental period can be elongated to the range of 1.5 to 2.5 seconds, through the installation of base isolators, resulting in the largest margin that can be achieved for period shifting. Clearly, base isolation is a suitable technique for low-rise and medium rise and less effective for high rise buildings, as the natural period of vibration of a building generally increases

with increasing height. The second factor which is for more important than the first is soil condition. It has been candidly shown that for stiff soil conditions, the base isolation is most applicable, whereas for soft soil strata, the application of base isolation is not helpful, but harmful.

X. RECOMMENDATIONS FOR VIBRATION ISOLATION AND CONTROL

The Indian Standard IS 13301 (1992) has recommended in great detail the measures and the material to be used for vibration isolation and control.

Figure 8 shows a plot using the static deflection required for the supported weight of the system to obtain any given level of transmissibility in the desired direction for various type disturbing frequencies of f the machinery might be derived. The region below the shaded line indicates amplification while the above this line suggests isolation. For effective isolation the frequency ratio shall be greater than as shown in Figure 9.

For shock and impulse loading

The IS codes has considered three types of pulse, namely, rectangular pulse, sinusoidal pulse and triangular pulse as shown in Figure 11 T_n = natural period

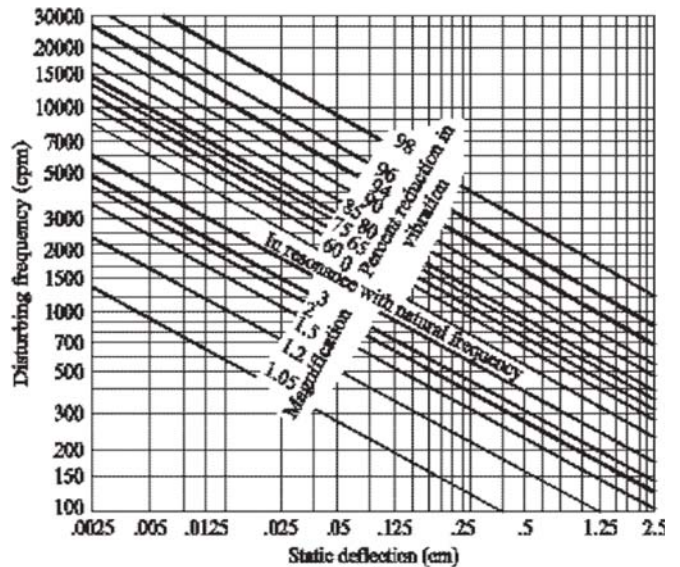

Figure 9. Isolation Efficiency of Resiliently Mounted System.

Types of vibration isolators

The commonly used types of vibration isolators are

- Metal helical
- Rubber
- Cork
- Air (pneumatic type)

However, it should be exerted that the isolators remain together in case the material (rubber, cork, etc.) fails. It must keep the

machine in the safe position with respect to support. As far as material protection is conserved, rubber as an isolator is quite useful for shear loading.

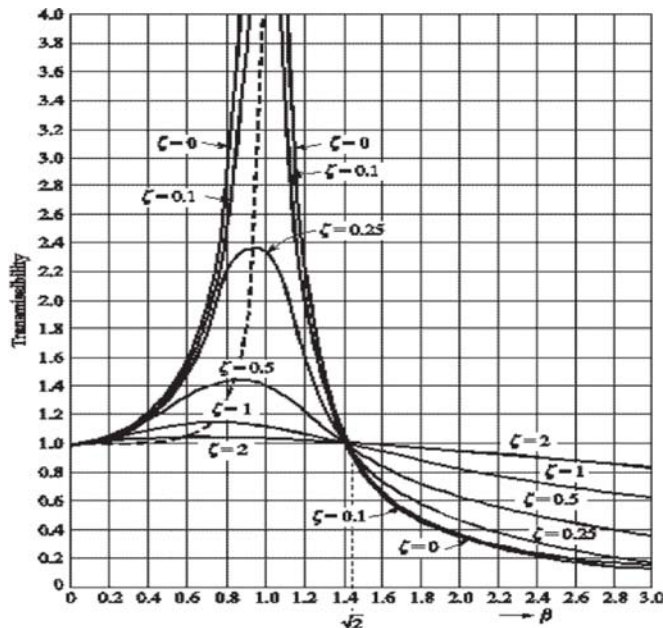

Figure 10. Variation of Transmissibility (Tr) with Frequency Ratio for Steady State Dynamic Loading.

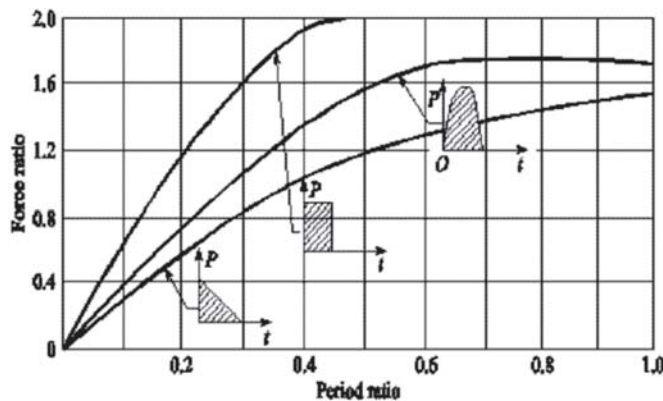

Figure 11. Variation of Transmissibility with Period Ratio for Pulse Loadings.

For effective vibration isolation, the natural frequency shall be preferably being.. It is preferred for low heat, light loads and high frequency oscillations. Cork is suitable for compressive loads. It is not perfectly elastic. At high loads it becomes more flexible. Metal springs can be used in all working conditions as they are not affected by air, water or oil or temperature variations. They are useful for high frequency ratios.

XI. SEISMIC ISOLATION AND ENERGY DISSIPATION SYSTEMS

The objective of seismic isolation and energy dissipation systems is to decouple the structure (bridges/buildings) from

the damaging components earthquake input. In other words, providing systems to prevent the structure from absorbing the seismic energy. The entire superstructure must be supported on discrete isolator whose dynamic characteristics are chosen to be uncoupling the ground motion. Some isolators are also designed to add substantial damping. Displacements and yielding are concentrated at the level of the isolation system/devices. This device can also be used at the base of the structure as part of an isolation system or in combination with braced frames or walls as energy dissipation devices. The devices can be classified as:

- Passive control system
- Active control system
- Hybrid control system
- Structural control system.

XII. DESIGN CONCEPT

The design concept of a seismic isolation system hinges on the following:

- Period of fixed-base structure
- Period of the isolation system
- Dynamic characteristics of the soil at site
- Input seismic spectrum
- Force-deformation relationship for isolation system.

Thus, a seismic isolating system may be defined as a flexible or sliding interface positioned between a structure and its foundation, for the purpose of developing the horizontal motions of the ground from the horizontal motion of the structure, thereby reducing earthquake damage to the structure and its contents.

Structures are not normally isolated from vertical earthquake motion. Generally speaking, vertical ground motion is of a smaller magnitude than horizontal motions. In addition, because structures must be designed to resist gravity loads they are inherently strong and stiff in the vertical direction, making isolating in the vertical direction of secondary importance.

Seismic isolation can have two advantageous effects on the seismic response of a structure: reduction of lateral forces in the superstructures, concentration of lateral displacements at the isolation interface.

The first effect is illustrated in Figure 12 which shows the smothered acceleration response spectra: the upper spectrum is for damping in the fixed base structure, and the lower spectrum is for developing in the isolated structure; note that the spectrum corresponding to damping in isolated structure is lower because of higher damping provided by the isolation system compared to the fixed system. The first mode period of a fixed base structure is shown by a vertical line on the left, the first mode period. Both of these effects reduce the acceleration response of the structure, and consequently the lateral force

in the structure. In other words, the presence of the isolation system concentrates lateral displacements at the isolating interface and minimizes lateral displacements in the superstructure.

XIII. ISOLATION SYSTEM

Isolation systems are basic elements in any practical seismic isolation system (Goyal and Ghanekar, 1997).

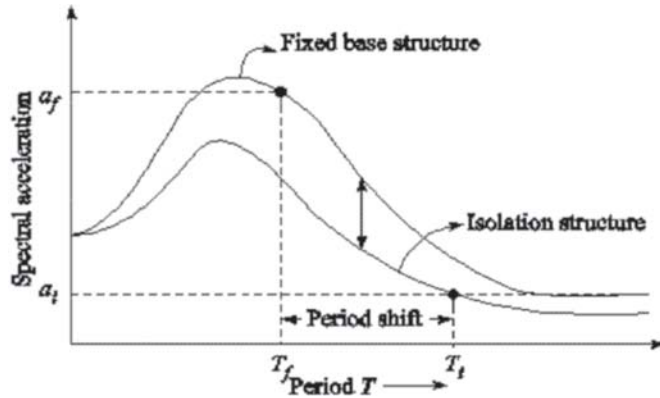

Figure 12. Response of a Fixed Base and Isolated Structure.

They may be started as follows:

- > A damper or energy despoliation so that the relative deflection between structure and ground can be controlled to a practical design level A means of providing rigidity under low (service) load levels such as wind and minor earthquakes.

Various types of elastomeric bearings can be gainfully employed as seismic isolation devices as they can provide flexibility to lengthen the period of vibration so as to reduce force response. Thus, in other words, structures have fundamental frequencies of vibrations within the band of frequencies where the energy of earthquake ground motion is the maximum. In such cases, a structure will amplify the seismic ground vibrations and produce accelerations within the structure that increases from the bottom of the structure to its top. Besides producing undesirable levels of acceleration in the structure, these amplified structural motions can cause severe stresses the structural elements and large relative motions between different part of the structure. This can result in permanent damage to parts of the structure or even to catastrophic collapse. The amplified acceleration throughout the structure acts on the occupants and contents of the structure and cause harm and damage to occupants and contents even when no structural damage occurs. Thus, the cost effective procedure to mitigate such effects is to isolate the structure from earthquake ground motions by the use of base isolators provided between the base and foundation of the structure. Seismic isolation is essentially a design technique, proposing the decoupling effects of the earthquakes. One of

the goals of seismic isolation is to shift the fundamental of the structure away from the dominant frequencies of earthquake ground motions and fundamental frequency of the fixed base structure. The other purpose of an isolation system is to provide an additional means of energy dissipation, there by reducing the transmitted acceleration into the structure. Jangid (2003) opined that the base isolation essentially decouples the structure from the ground motion earthquake excitation.

Lead Rubber Bearing

Since its invention in 1976 by far the most common system for seismically isolating bridges in New Zealand, Japan and USA has been the lead rubber bearing as shown in Figure 13 (a). Usually, the lead rubber bearings are isolated installed between the bridge superstructure and supporting pier (Robinson, W.H. 1982). One of the reasons for popularity of this mode of seismic isolation is that the fact that it combines the function of isolation and energy dissipation in single compact unit, while supporting the weight of the superstructure and providing on inelastic restoring force. Figure 13. (a) Shows the bearings consisting of sandwich of steel plates separated by layers of rubber vulcanized together with lead plug inserted in the centre. Bearings are simple devices which withstand movements (generally six degrees of freedom of movements in terms of translation and rotation). In bridges, bearings are designed to transmit all vertical loads and appropriate horizontal forces. In Figure 13.(a), the lead plug is subjected to a uniform shear deformation under horizontal loadings, providing considerable

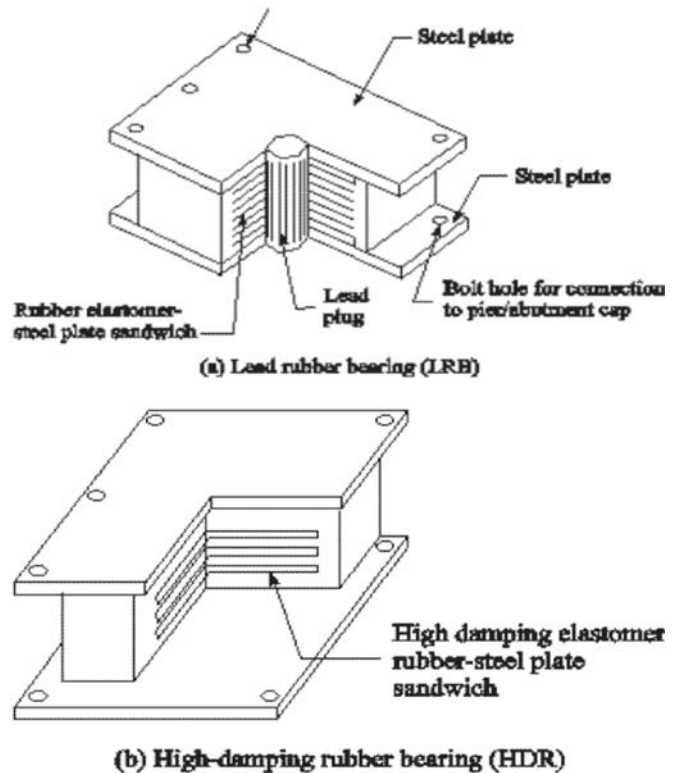

Figure 13. Seismic Isolation Devices.

energy dissipating capacity when it yields under severe earthquake loading. The good performances of the lead rubber bearing is due to the fact that at ambient temperatures the lead becomes hot worked so that during plastic deformation it continually recovers its mechanical properties by the process of recovery recrystallization and grain growth.

Also, the efficient use of the lead in providing the hysteresis loop is ensured by the lead being tightly confined by steel.. is forced to deform plastically in pure shear. Although the bearing does not fail up to shear of 170% the upper limit used for new design generally accepted to be 100%, and values up to 150% are accept to retrofit for a limited number of cycles.

XIV. CONCLUSION

Damping reduces the transient from vibrations and, consequently, there is a delay of vibrations. Damping is used in passive isolators to reduce the amount of amplification at the natural frequency. However, increasing damping tends to reduce isolation at higher frequencies. As damping is increased, transmissibility roll-off decreases.

XV. REFERENCES

- [1]. Chen, W.F., and C. Scawthorn (2002), *Earthquake Engineering Handbook*, CRC Press, Florida, USA.
- [2]. Chen, W.F., and M.L. Eric (2005), *Earthquake Engineering For Structural Design*, CRC Press, USA.
- [14] Goyal, J.K., and V.K. Ghanekar (1977), Seismic Protection of Bridges Through Isolating Devices, International Seminar on New Trends in Highway Constructions, *Theme II*, New Delhi, pp. 155–167.
- [3]. Chetaev, N.G. (1961), *The Stability of Motions*, Pergamon Press, New York.
- [4]. Chopra, A.K. (2002), *Dynamics of Structures*, Prentice-Hall of India, New Delhi.
- [5]. Housner, G. W. et al.,(1997), “Structural Control: Past, Present and Future”, *Journal of the Engineering Machining Division*. (ASCE), Vol. 123, pp. 897–917.
- [6]. Housner, G. (1963), “The Behavior of Inverted Pendulum
- [7]. Iemura, H., and Igarashi (1996), “Non-linear Active Control Experiment of a Real Size Frame Structure”, *Proc. Second International Workshop on Structural Control*, Hong Kong, pp. 241–252.
- [8]. Prasad, Bharat Bhushan (1984), “Dynamic Stability of Beam on Elastic Foundation”, *Proc. 5th (ASCE) Specialty Conference*, Wyoming, USA, pp. 1476–1479.
- [9]. Prasad, Bharat Bhushan (2003), “Seismic Hazard Analysis and Vulnerability Studies of Seismic Prone Areas of Bihar”, *Workshop on Retrofitting of Structures*, Department of Earthquake Engineering and Indian Society of Earthquake Engineering, IIT Roorkee, pp. 45–65.
- [10]. Prasad, Bharat Bhushan, and B.P. Sinha (1987), “Dynamic Response of Beam on Elastic Foundation Impact Loading”, *Transactions of the 9th SmiRT Conference on Structure Mechanics in Reactor Technology*, Lausanne, pp. 211–217.
- [11]. Prasad, Bharat Bhushan and N.S.V. Kameswar Rao (1979), “Beam Foundation Interaction due to Impact Loads”, *Indian Geotechnical Journal*, New Delhi, Vol. 9, pp. 257–278.
- [12]. Prasad, Bharat Bhushan and N.S.V. Kameswar Rao (1975), “Impact Loads on Beam on Elastic Foundation”, *3rd SmiRT Conference on Structure Mechanics in Reactor Technology*, London, pp. J5/8.
- [13]. Prasad, Bharat Bhushan and N.S.V. Kameswar Rao (1980), “Response of Beams on Elastic Foundation to Dynamic Loading”, *Journal of the Engineering Mechanics Division*, 106(EM1), USA, pp. 179–185.
- [15]. Robinson, W.H., and A.E. Tucker (1977), “Lead–Rubber Shear Dampers”, *Bulletin of New Zealand Society for Earthquake Engineering*, 10(3), pp. 151–153.
- [16]. Robinson, W.H., (1982), “Lead–Rubber Hysteretic Bearings suitable for Protecting Structures during Earthquakes”, *Earthquake Engineering and Structural Dynamics*, 1(40), pp. 593–604.
- [17]. Robinson, W.H., (1982), “Lead–Rubber Hysteretic Bearings suitable for Protecting Structures during Earthquakes”, *Earthquake Engineering and Structural Dynamics*, 1(40), pp. 593–604.
- [18]. Robinson, W.H., and W.J. Consins (1982), “Recent Developments in Lead Dampers for Base Isolation”, *Pacific Conference on Earthquake Engineering*, New Zealand, Vol. 2, pp. 2279–2283.

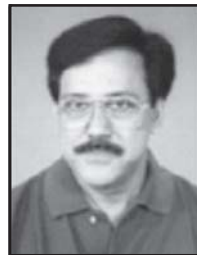

Dr. Bharat Bhushan Prasad is working as Professor & Head, Department of Civil Engineering at AKGEC. He graduated in Civil Engineering in 1966 winning Gold Medal of Patna University. Obtained M.Tech. in Civil Engineering with specialization in Soil Dynamics from IIT Kanpur in 1975 and Ph.D in 1987. Indian Geotechnical Society, New Delhi awarded him Gold Medal for best research paper on Soil dynamics.

Authored two books on Soil Dynamics and Earthquake Engineering (PHI New Delhi). He has guided several research scholars for M.Tech & Ph.D and published twenty four papers in International Journals/Symposia proceedings.